

Inkjet Plotter for Digital Printing to Textile

Textile Jet

Tx3-1600

Mimaki



From "Textile Print" to "Textile Art"
The Tx3-1600 will amaze you.



A safety cover is provided.



New Textile Frontier Now STR

From soft designs to photorealistic designs,

*The Tx3-1600 makes designers free by supporting stretchable material
to turn textiles into art.*

Boosting work efficiency through unattended operation, the Tx3-1600 opens up new fields.

RETCHABLE Materials

Revolutionary system opens up creation of beauty.

1 Supply mechanism

The supply mechanism is capable of feeding large-diameter heavy fabric. Moreover, this mechanism also supports thin materials or stretchable materials by sticking to the belt with a constant tension. The tension can be adjusted according to the fabric's weave, thickness, and stretchability.

2 Wrinkle removal mechanism

A wrinkle removal roller stretches the fabric outwards, resulting in less wrinkles.



3 Conveyor belt mechanism

Since the conveyor belt does not pull the fabric, printing stretchable materials is possible. This also has the effect of minimizing fabric expansion/shrinking caused by ink absorption.

4 Washing mechanism

The conveyor belt can be washed with water and a brush through direct connection to a water supply and water exhaust system. Washing through the use of a simple circulation type water tank is also possible.



5 Drying mechanism

Once the fabric has been printed, it can be dried with a heater, reducing reverse side bleeding during take-up.

6 Take-up mechanism

Both face-in take-up and face-out take-up can be selected according to the process after printing. (winding up to 38 kg, 270 mm external diameter, is possible)

7 ANR (automatic nozzle recovery) system

The ink squirting status can be monitored and the heads will be cleaned up whenever necessary, thereby reducing printing problems caused by clogged heads.

Fabric Path Configuration Diagram

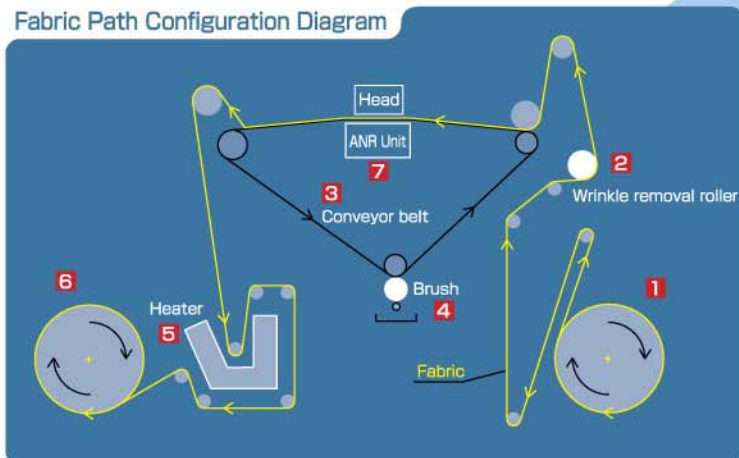

Software that gives free play to your imagination.

The Tx Link suite of software provided as standard with the Tx3-1600 frees up your imagination, from design to color arrangement.

Tx Link Design (Windows/Macintosh compatible)

This is plug-in software that supports efficient textile design with Adobe Photoshop.* Adobe Photoshop is sold separately.

- Various image editing operations can be performed, including the conversion of full-color images to a smaller number of desired colors, noise removal, and color replacement.
- Repeat patterns can be created while watching previews with the designated step size.
- Four color variations can be simultaneously simulated.
Images can be output to an ordinary color printer for presentation purposes.

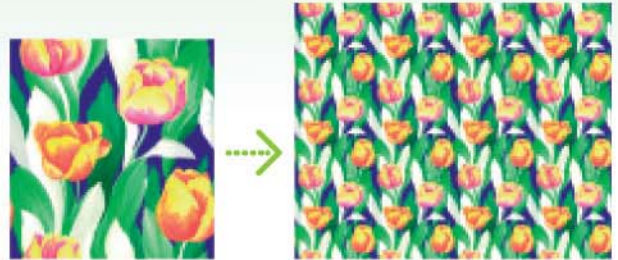

Repeat patterns are assembled without seams.

Tx Link Color Book / Tx Link Book Editor (Windows compatible)

This is software to generate color replacement files for variable color scheme printing.

- You can specify original ink colors for the colors used in the image.
- You can register original ink colors to a color book.
- In addition to original ink colors, standard colors provided by Tx Link are also available for use.



Image changes through color replacement are possible.

Tx Link Print (Windows compatible)

This is software for printing design data.

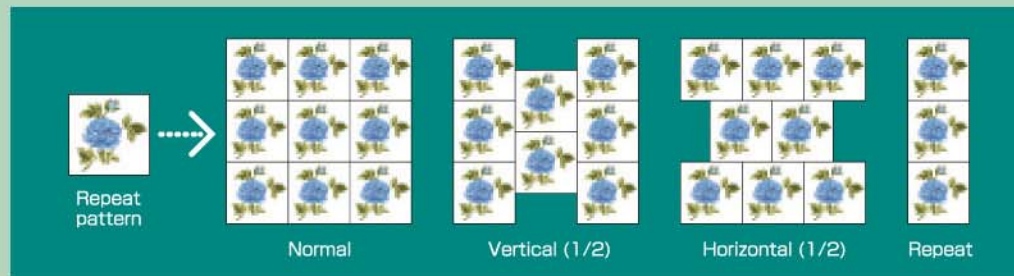

- Repeat images of the designated step size can be output.
- The ink consumption amount can be predicted for each image data.
- ICM2.0 compatible color management is included.
- Color replacement printing, using color replacement files created with Tx Link Color Book, can be performed.
- Layout settings
 - Enlargement/reduction, mirror
 - Step settings: None, normal, horizontal, vertical, repeat, sequence copy
- Supported file formats
TIFF, JPEG, BMP
Supported color modes: CMYK (full color), RGB (full color, index color)

ARTING

The Tx3-1600's new functions allow you to express your vision.

"Textile art" made up by technology.

Stretchable materials ... More creativity

- Supports stretchable materials by endless belt.
- Supports also thin materials by supply mechanism.

Unattended operation ... Guarantees long-duration printing

- Loading big 2 liter/color ink tank.
- ANR (automatic nozzle recovery) system.
- Supporting of large rolls of up to 270 mm.

Ink system

● Uses large ink cartridges

Overnight operation and long-duration printing are supported by two sets of 1,000 cc cartridges for each color. (Conventional 220 cc cartridges of the Tx2-1600 can be used.)



● Toggle switch

Cartridges can be replaced even during operation by using the automatic toggle switch for supply cartridges.

● Newly developed ink end detection function

This function reduces ink waste by allowing ink to be used to the last drop.

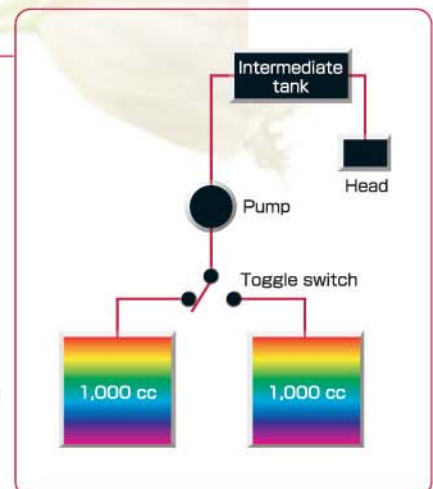

Specifications

Heads	Type	Piezo electric drop on demand	
	Head configuration	180 dpi x 360 nozzles x 8 colors	
	Height	Adjustable between 1.3 mm to 10 mm (0.05" to 0.39") from belt surface	
Printing mode *1	Pass	2/3/4/6/8/12/16 passes	
	Direction	Uni / Bi direction	
	Scan speed	Normal / High	
	Resolutions	720x720 dpi, 360x720 dpi, 360x540 dpi, 360x360 dpi	
	Inks	Type	Acid dye / Reactive dye
Inks	Supply	Double cartridge automatic switching & intermediate tank	
	Capacity	max. 1,000 cc x 2 + 40 cc (approx. 2.2 kg (4.9 lbs))	
	Perpendicularity	±0.5 mm / 1,000 mm angle (±0.02" / 39.4" angle)	
Fabric skew	5 mm / 10 m or less (0.2" / 393.7" or less) : in case of cloth roll left / right edge winding displacement of 5 mm (0.2") or less		
Usable fabrics *2	Width	200 mm to 1,650 mm (approx. 8" to 65")	
	Roll external diameter	φ270 mm (φ10.6") or less	
	Roll weight	38 kg (83.8 lbs) or less	
	Settable paper tube	φ50mm to φ79 mm (φ2" to φ3"), left / right reference position changeable	
	Printing face	Face-in / Face-out	
Printing	Effective area	1,620 mm (64")	
	Margin (roll)	Leading edge: 2 m (7.9") (during initial setting to take-up device) Trailing edge: max 2.8m (11") (when end of fabric is removed from paper tube)	
Interface	IEEE-1394 / IEEE-1284		
Safety standards	VCCI Class A, FCC Class A / UL 60950 CE markings (EMC, low voltage directive) / CB report		
Power	Body	AC100 V to 240V±10% (auto voltage)	50/60 Hz±1 Hz
	Heater	AC100 V to 120 V/200 V to 240 V±10% (switchable)	50/60 Hz±1 Hz
	Blower	AC100 V to 120 V or AC200 V to 240 V±10% (factory preset)	50/60 Hz±1 Hz
Power consumption	Body	6 A or less (AC 100 V) / 3 A or less (AC 200 V)	
	Heater	12 A or less (AC 100V) / 6.5 A or less (AC 220 V)	
	Blower	5.5 A or less (AC 100 V) / 3 A or less (AC 220 V)	
Operating environment	Available temp	15 °C to 30 °C (59°F to 86°F)	
	Humidity	35 to 65 % Rh (No condensation)	
	Guaranteed temp	18 °C to 25 °C (64.4°F to 77°F)	
	Dust	Office level	
Dimensions(WxDxH)/weight	3,250 mm x 1,550 mm x 1,400 mm (128" x 61" x 55") or less 660 kg (1,455 lbs) or less		

*1: Some combinations of Pass, Direction, Scan Speed, and Resolutions are not supported.
 *2: The following types of fabric cannot be used. <1> Fabrics that do not wind well; <2> Fabrics with considerable moisture-related expansion/shrinking; <3> Fabrics with a large gummed portion that sags; <4> Fabrics that sag in the middle portion; <5> Fabrics with a narrow weave; <6> Particularly hard fabrics; <7> Fabrics that are twisted due to improper pre-processing.
 Fabrics require pre-processing for inkjet printing before printing, as well as post-processing such as steam and washing after printing.

Installation space

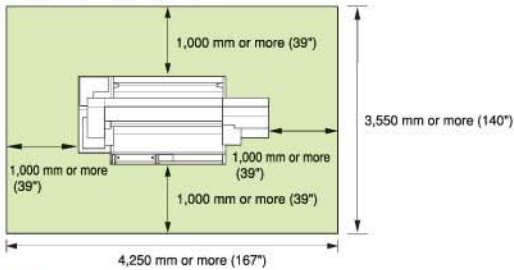

External dimensions

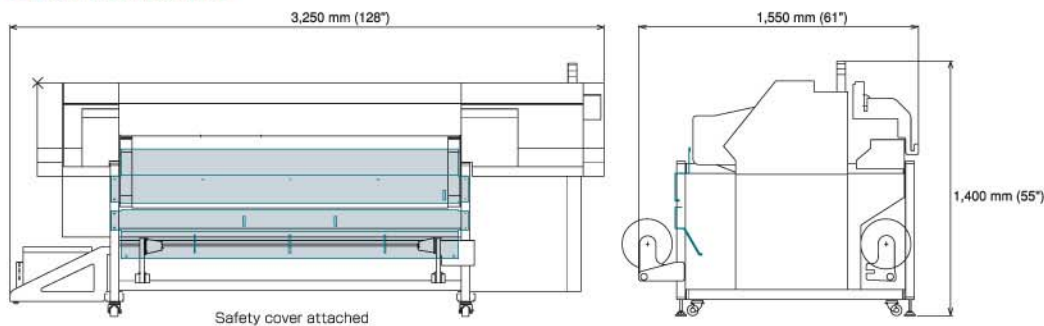

● There are restrictions on the fabrics that can be printed. ● Specifications are subject to change without notice. ● All trademarks or registered trademarks are the property of the respective owners. ● Some of the screens and printing samples in this catalog are artificial renderings. ● Inkjet printers print using extremely fine dots, so colors may vary slightly after replacement of the printing heads. Also note that if using multiple printer units, colors may differ slightly among the units due to slight individual differences among the units.

Inks

Color	Product Code	
	220 cc (Approx. 0.24 kg)	1,000 cc (Approx. 1.1 kg)
Black	SPC-0355K	SPC-0392K
Cyan	SPC-0355C	SPC-0392C
Magenta	SPC-0355M	SPC-0392M
Yellow	SPC-0355Y	SPC-0392Y
Light magenta	SPC-0355LM	SPC-0392LM
Light cyan	SPC-0355LC	SPC-0392LC
Gray	SPC-0355GR	SPC-0392GR
Blue	SPC-0355BL	SPC-0392BL
Red	SPC-0355R	

Color	Product Code	
	220 cc (Approx. 0.24 kg)	1,000 cc (Approx. 1.1 kg)
Black	SPC-0357K	SPC-0393K
Cyan	SPC-0357C	SPC-0393C
Magenta	SPC-0357M	SPC-0393M
Yellow	SPC-0357Y	SPC-0393Y
Light magenta	SPC-0357LM	SPC-0393LM
Light cyan	SPC-0357LC	SPC-0393LC
Gray	SPC-0357GR	SPC-0393GR
Blue	SPC-0357BL	SPC-0393BL
Orange	SPC-0357OR	SPC-0393OR
Red	SPC-0357R	SPC-0393R
Golden yellow	SPC-0357GY	SPC-0393GY

* The 1,000 cc cartridge will be on sale soon. (As of July 2004)

Print speed

360x360 dpi	Fast	27.0 m ² /h
	Standard	15.0 m ² /h
	Clear	8.1 m ² /h
360x540 dpi	Fast	19.3 m ² /h
	Standard	10.4 m ² /h
	Clear	5.4 m ² /h
720x720 dpi	Fast	10.0 m ² /h
	Standard	5.5 m ² /h
	Clear	2.7 m ² /h

* 8-color mode: Printing speed for a printing width of 1,600 mm and bi-directional printing.
 The printing resolution and printing speed may be restricted by the type of fabric and the pre-processing status.
 The more narrow the printing width, the longer the printing time, even for the same printing area.

All our products are manufactured under our quality assurance system certified by ISO9001



Mimaki USA, Inc. www.mimakiusa.com

140 Satellite Boulevard NE, Suwanee, Georgia 30024-7128
 Atlanta 888-530-3988 / Boston 888-530-3986 / Los Angeles 888-530-3987

DEALER :

MIMAKI ENGINEERING CO., LTD.

TKB Gotenyama Bldg. 5-9-41 Kita Shinagawa, Shinagawa-ku, Tokyo 141-0001, Japan.
 Phone:+81-3-5420-8671 Fax:+81-3-5420-8687 URL http://www.mimaki.co.jp